

General Description

The AAT3620 BatteryManager™ is a member of AnalogicTech's Total Power Management IC™ family. With the many functions added to mobile devices such as color display, camera with flash, organizer, video, etc, the battery capacity must keep pace with the power requirements. The AAT3620 is the ideal solution for high capacity Li+ batteries and can supply up to 2.0A charge current with minimal thermal impact to the system.

The AAT3620 is a PWM switch mode / linear charger with high charge efficiency at the full constant current (fast charge) rate. Based on a 1.5MHz PWM step-down "buck" converter, the AAT3620 PWM switch mode controls the constant current charge mode up to 2.0A, and automatically switches to linear mode charging during the battery conditioning low level current and the light load end of charge current termination region. The full charge rate and the end of charge current can be programmed with separate external resistors. A shared charge current indication pin is available for a Coulomb counter.

Battery charge temperature and charge state are fully monitored for fault conditions. In the event of an over-current, over-voltage, short-circuit or over-temperature failure, the device will automatically shut down. A status monitor output pin is provided to indicate the battery charge status and power source status through a display LED.

The AAT3620 is available in a thermally enhanced, space-saving 14-pin 3x3mm TDFN package that includes all essential components for a switch-mode battery charger.

Features

- 4.3V~6.0V Input Range
- Up to 2.0A Charge Current Capability
- 1.5MHz PWM/Linear Charger
- Over 90% Full Rate Charge Efficiency
- Integrated Switching Device
- Integrated Sense Resistor
- Built-in Reverse Blocking Feature
- Battery Preconditioning/Constant Voltage/Constant Current Charge Mode
- Programmable End of Charge Current
- 1% Constant Voltage Mode Regulation
- Built-in Programmable Charging Timer
- Charge Current Indication Pin
- Over-Voltage, Over-Current, and Over-Temperature Protection
- Battery Over-Temperature Protection
- Power-On Reset and Soft-Start
- TDFN33-14 Package

Applications

- Digital Camcorders
- Point of Service (POS)
- Portable DVD Players
- Portable Hand-held Solutions
- Portable Media Player

Typical Application

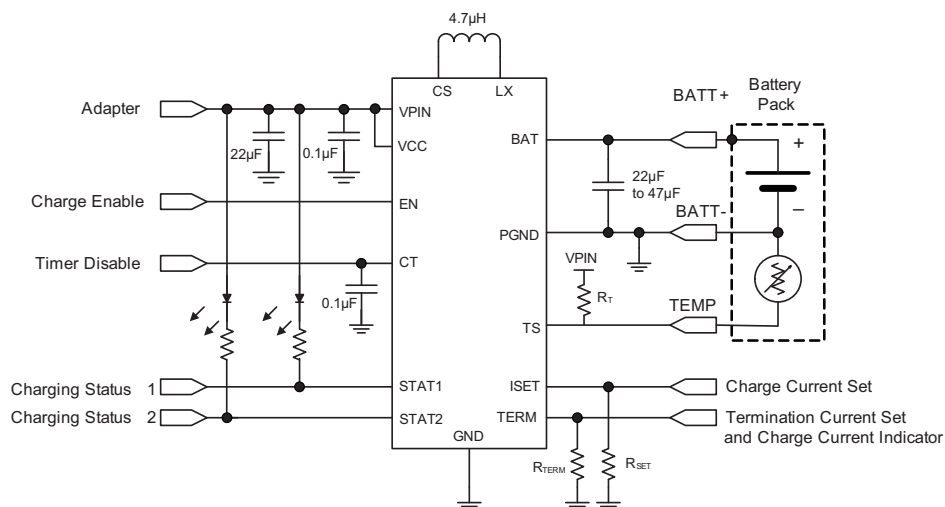

Pin Description

Pin#	Name	Type	Function
1	VPIN	In	Adapter power input.
2	PGND	Ground	Power ground
3	GND	Ground	Analog ground connection.
4	VCC	In	Supply Input
5	EN	In	Charge enable input, active high, with internal pull-up (to VPIN).
6	ISET	In	Connect RSET resistor to pin to set constant current charge current.
7	CT	In/Out	Timer pin: connect timing capacitor here for charge timer function; connect to ground to disables the timer function.
8	STAT2	Out	Battery charge status 2 indicator pin to drive an LED, open-drain.
9	STAT1	Out	Battery charge status 1 indicator pin to drive an LED, open-drain.
10	TERM	In/Out	Connect RTERM resistor to pin to set termination current. Charging current can be monitor with this pin. Leave OPEN to set to 200mA default termination current.
11	TS	In/Out	Battery pack temperature sensing input. To disable TS function, pull up to V _{CC} through 10k resistor.
12	BAT	Out	Battery positive terminal connecting pin.
13	CS	In	Return pin for inductor for internal current sensing
14	LX	In/Out	Switching node.
EP	EP	Ground	The exposed thermal pad (EP) must be connected to board ground plane and pins 2 and 3. The ground plane should include a large exposed copper pad under the package for thermal dissipation (see package outline).

Pin Configuration

**TDFN33-14
(Top View)**

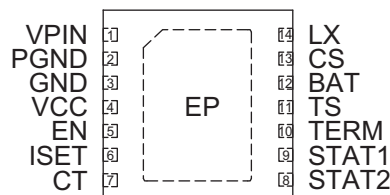

Absolute Maximum Ratings¹

Symbol	Description	Value	Units
V _P	VPIN, LX	-0.3 to 6.5	V
V _N	Other pins	-0.3 to V _P + 0.3	V
T _J	Operating Junction Temperature Range	-40 to 150	°C
P _D	Maximum Power Dissipation	2.5	W
T _{LEAD}	Maximum Soldering Temperature (at Leads)	300	°C

Thermal Information

Symbol	Description	Value	Units
θ _{JA}	Maximum Thermal Resistance (3x3mm TDFN-14) ²	50	°C/W
P _D	Maximum Power Dissipation ³	2	W

1. Stresses above those listed in Absolute Maximum Ratings may cause permanent damage to the device. Functional operation at conditions other than the operating conditions specified is not implied. Only one Absolute Maximum Rating should be applied at any one time.

2. Mounted on an FR4 board.

3. Derate 2.7mW/°C above 25°C ambient temperature.

Electrical Characteristics¹

$V_{IN} = 5.5V$, $T_A = -25^{\circ}C$ to $85^{\circ}C$; unless otherwise noted, typical values are at $T_A = 25^{\circ}C$.

Symbol	Description	Conditions	Min	Typ	Max	Units
Operation						
V_{IN}	Adapter Input Voltage		4.3		6.0	V
V_{VIN_UVLO}	Input Under-Voltage Lockout	V_{PIN} Rising Hysteresis	3.5		4.3	V
V_{VIN_SLEEP}	Input Sleep Voltage	No Charge if $V_{VIN} < V_{VIN_SLEEP}$		$V_{BAT} + 0.05$	$V_{BAT} + 0.2$	V
I_{VIN_OP}	Operating Supply Current	EN = High, Charge Current = 200mA			5	mA
I_{VIN_STBY}	Standby Supply Current	EN = High, No Charge			2	mA
I_{VIN_SHDN}	Shutdown Supply Current	EN = Low, LX Floating			10	μA
I_{FWD_LKG}	Forward Leakage Current, Measured from LX to Ground	EN = Low, LX = 5.5V			1	μA
I_{REV_LKG}	Reverse Leakage Current, Measured from LX to V_{IN}	EN = Low or High, $V_{IN} = 0V$, LX = 5.5V			1	μA
I_{BAT_LKG}	Bat Pin Leakage Current	$V_{BAT} = 4.2V$, $V_{IN} = 0V$ or open			1	μA
$R_{DS(ON)}$	Internal PMOS On Resistance	$V_{IN} = 5.5V$		170	300	m Ω
	Internal NMOS On Resistance	$V_{IN} = 5.5V$		120	250	m Ω
f_{SW}	PWM Switching Frequency	$V_{BAT} = 3.6V$	1.2	1.5	1.8	MHz
Charge Regulation						
V_{BAT_REG}	Output Charge Voltage Regulation		4.158	4.20	4.242	V
t_{SOFT_START}	Charging Soft-Start Delay	Delay of Charge from EN, or V_{VIN_UVLO} , or V_{VIN_ADPP}		100		μs
V_{BAT_BC}	Battery Conditioning Battery Voltage Threshold	Preconditioning Battery Charge when $V_{BAT} < V_{BAT_BC}$	2.4	2.6	2.8	V
I_{CH_BC}	Battery Conditioning Charge Current	When $V_{BAT} < V_{BAT_BC}$		$I_{CH_CC} \times 0.1$		A
$I_{CH_BC_TYP}$	Typical Battery Conditioning Charge Current Setting Range		100		200	mA
t_{CH_BC}	Battery Conditioning Time Out	Stop Charge if Preconditioning Time is more than t_{CH_CV}	-15%	$0.25 \times C_{CT}$	+15%	Minute/nF
I_{CH_CC}	Constant-Current (Cc) Battery Charge Current	When $V_{BAT_BC} < V_{BAT} < V_{BAT_REG}$	-15%	I_{CH_CC}	+15%	%
$I_{CH_CC_TYP}$	Typical Constant-Current (Cc) Battery Charge Current Setting Range		1		2	A
t_{CH_CCFAST}	Fast Constant Current Charge Time Out (Bccc + Ccv)	Stop Charge if Fast Charge Time is more than t_{CH_CCFAST}	-15%	$0.02 \times C_{CT}$	+15%	Hour/nF
t_{CH_CV}	Constant Voltage Charge Time Out	Stop Charge if Charge Time is more than t_{CH_CV}	-15%	$0.03 \times C_{CT}$	+15%	Hour/nF
V_{BAT_RCH}	Battery Recharge Voltage Threshold	If V_{BAT} Falls Below V_{BAT_RCH} , Recharge Starts		$V_{BAT_REG} - 0.1$		V
I_{TERM}	Charge Termination Threshold Current	Terminate CV Charge if $I_{CH} < I_{TERM}$	-10	$R_{TERM} \times 10^{-6}$	10	%
I_{TERM_TYP}	Typical Termination Threshold Current Setting Range		50		200	mA

1. Specification over the $-25^{\circ}C$ to $+85^{\circ}C$ operating temperature range is assured by design, characterization and correlation with statistical process controls.

Electrical Characteristics¹

$V_{IN} = 5.5V$, $T_A = -25^{\circ}C$ to $85^{\circ}C$; unless otherwise noted, typical values are at $T_A = 25^{\circ}C$.

Symbol	Description	Conditions	Min	Typ	Max	Units
Logic and Status Input/Output						
V_{HIGH}	EN Input Low Threshold		1.6			V
V_{LOW}	EN Input Low Threshold				0.4	V
I_{EN}	EN Pin Supply Current	$EN = V_{IN}$		0.1	1	μA
		$EN = 0V$		0.6	10	μA
I_{SLEAK}	STAT1, STAT2 Pin Leakage Current	When output FET is off			1	μA
I_{STATX}	STAT1 and STAT2 Pin Current Sink Capability				10	mA
t_{STAT_PULSE}	STAT Pulse Width	In fault conditions		0.5		s
f_{STAT_FLASH}	STAT Pulse Frequency	In fault conditions		1		Hz
Protection						
V_{BAT_OVP}	Battery Over-Voltage Protection Threshold	No charge if $V_{BAT} > V_{BAT_OVP}$		$V_{BAT_REG} + 0.2$		V
I_{OCP_LMT2} $V_{BAT_OVP} I_{DATA}$	Over-Current Protection Threshold and Limit		2.46	3.0	4.0	A
V_{TS1}	TS Hot Temperature Fault	Threshold	29.1	30	30.9	% V_{IN}
		Hysteresis		50		mV
V_{TS2}	TS Cold Temperature Fault Threshold	Threshold	58.2	60	61.8	% V_{IN}
		Hysteresis		50		mV
T_{TH}	Thermal Shutdown			140		$^{\circ}C$
T_{TH_HYS}	Thermal Shutdown Hysteresis			15		$^{\circ}C$
V_{CT_DIS}	Charge Timer Disable Threshold	No timer out if CT voltage holds to be less than V_{CT_DIS}			0.4	V

1. Specification over the $-25^{\circ}C$ to $+85^{\circ}C$ operating temperature range is assured by design, characterization and correlation with statistical process controls.

Typical Characteristics

Charging Current vs. Battery Voltage

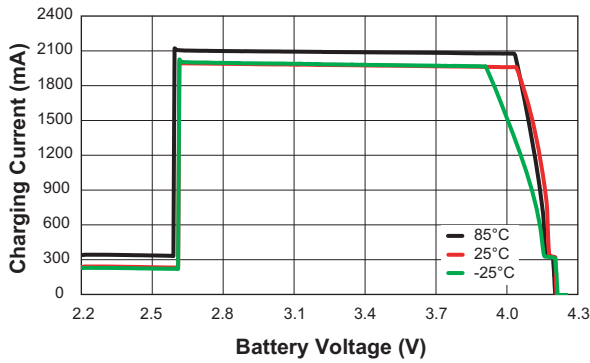

Constant-Current Charge Mode

Current vs. I_{SET} Resistor
(V_{IN} = 5V; V_{BAT} = 3.5V)

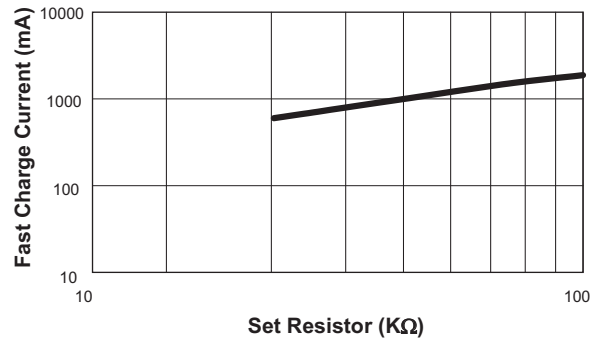

Termination Current vs. Temperature

(V_{IN} = 5V; R_{TERM} = 49.9KΩ)

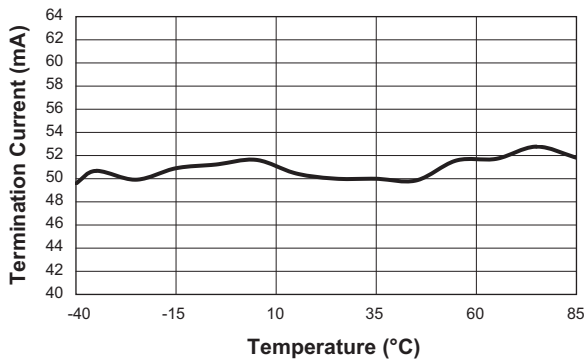

Recharge Voltage vs. Temperature

(V_{IN} = 5V)

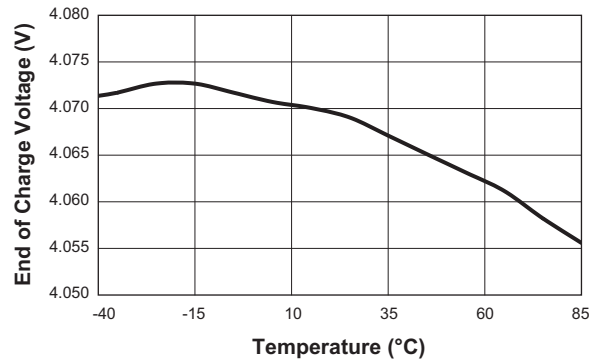

Preconditioning Rising Threshold Voltage vs. Temperature

(V_{IN} = 5.5V)

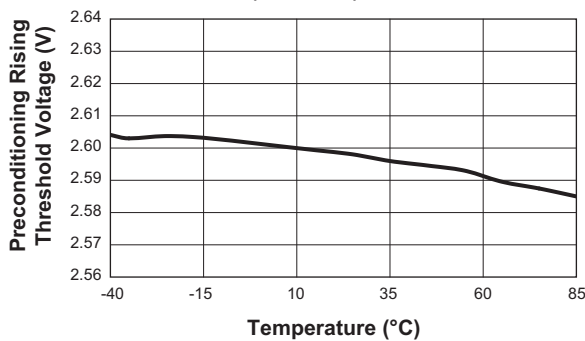

Shutdown Current vs. Input Voltage

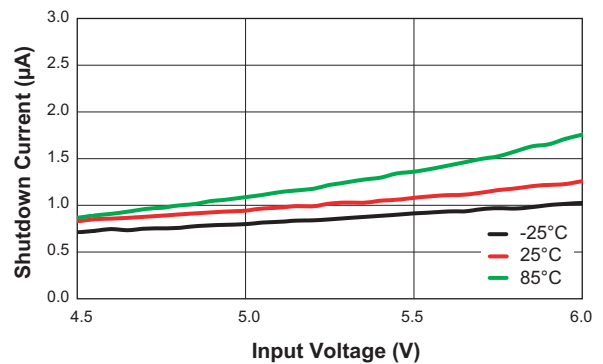

Typical Characteristics

Charge Current vs. Input Voltage
(T = -25°C)

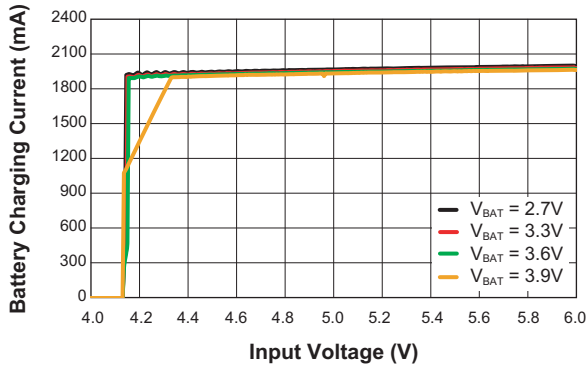

Charge Current vs. Input Voltage
(T = 85°C)

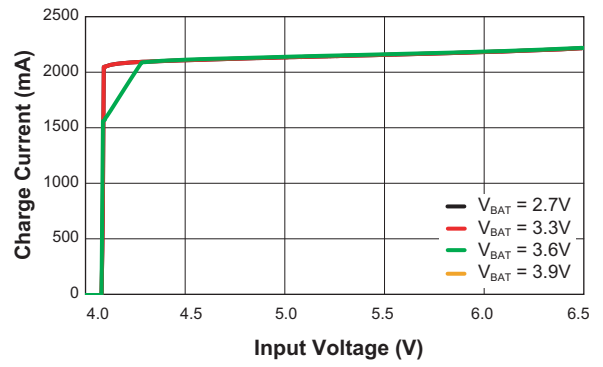

Functional Block Diagram

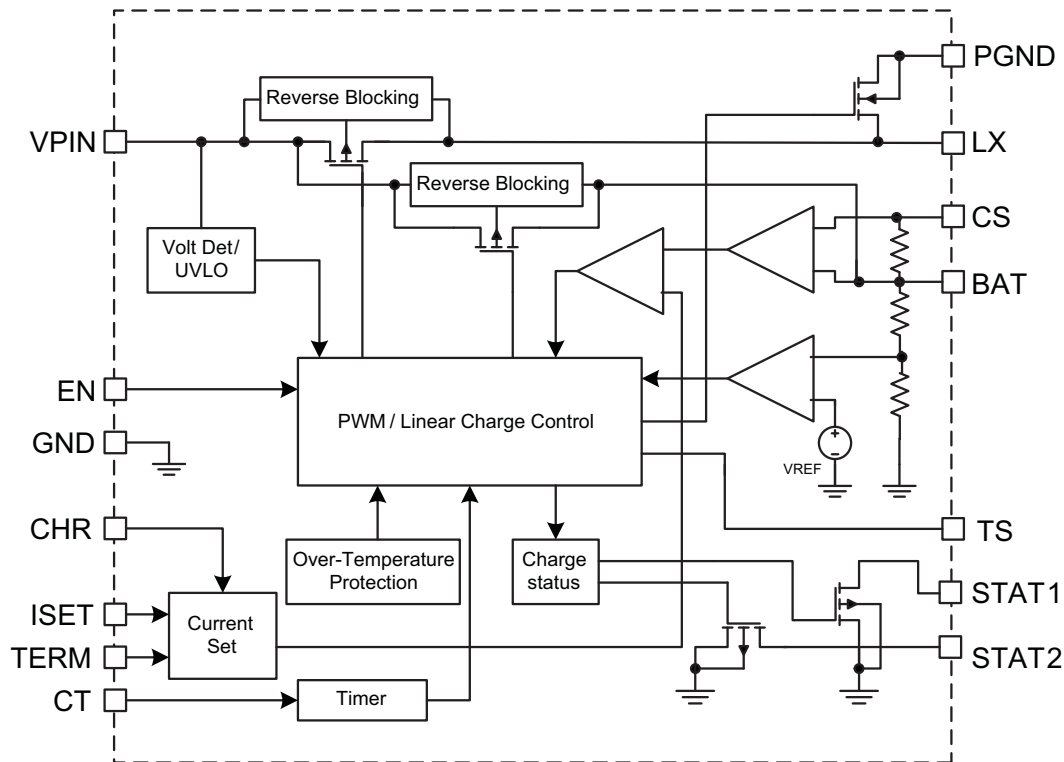

Functional Description

Control Loop

The AAT3620 uses an average current mode step-down converter to implement the DC/DC switch-mode converter function during constant current mode charging. The technique of average current mode control overcomes peak current control problems by introducing a high gain integrating current error amplifier into the current loop. Average current tracks the sensed output current with a high degree of accuracy and the noise immunity is excellent. The oscillator saw-tooth ramp provides compensation so no slope compensation is required for duty cycle exceeding 50%. The high gain of the current error amplifier at DC accurately programs the output. The switching charger works in continuous current mode PWM only. There is a soft start before entering constant current charging mode and the charger re-enters linear operation in constant voltage mode when the charge current drops below 300mA.

Linear vs. Switching Battery Charging

The AAT3620 performs battery charging using the benefits of the step-down or "buck" architecture to multiply the input current when stepping down the output voltage. This property is expressed mathematically in the comparison below, and provides the ability to maximize battery charging from current limited devices, as well as greatly decrease power and heat related dissipation.

Linear Charging

Linear charge current relationship*:

$$I_{\text{BATL}} = I_{\text{IN}}$$

Efficiency of linear charger:

$$n_L = \frac{V_{\text{BAT}}}{V_{\text{IN}}}$$

* Equation does not take into account thermal foldback.

Switch-Mode Charging

Switch-mode current relationship:

$$I_{BATS} = \frac{n_s \cdot V_{IN} \cdot I_{IN}}{V_{BAT}}$$

Where $n_s = 90\%$.

Example: Power Savings

Conventional Linear Charger IC:

$$P_D = (V_{IN} - V_{BAT}) \cdot I_{BAT} = (5 - 3.5) \cdot 0.5 = 0.75W$$

Switch-Mode Charger IC:

$$P_D = V_{BAT} \cdot I_{BAT} / \eta - V_{BAT} \cdot I_{BAT} = 3.5 \cdot 0.5 / 0.9 - 3.5 \cdot 0.5 = 0.195W$$

Adapter Input Charge Inhibit and Resume

The AAT3683 has a UVLO and power on reset feature so that if the input supply to the ADP pin drops below the UVLO threshold, the charger will suspend charging and shut down. When power is re-applied to the IN pin or the UVLO condition recovers, the system charge control will assess the state of charge on the battery cell and will automatically resume charging in the appropriate mode for the condition of the battery.

Input/Output Capacitor and Inductor

The AAT3620 contains a high performance 2A, 1.5MHz synchronous step-down converter. The step-down converter operates to ensure high efficiency performance over all load conditions. It requires only 3 external power components (C_{IN} , C_{OUT} , and L).

Apart from the input capacitor, only a small L-C filter is required at the output side for the step-down converter to operate properly. Typically, a 4.7µH inductor such as the Würth 7447789004 and a 22µF to 47µF ceramic output capacitor is recommended for low output voltage ripple and small component size. Ceramic capacitors with X5R or X7R dielectrics are highly recommended because of their low ESR and small temperature coefficients. A 22µF ceramic input capacitor is sufficient for most applications.

Battery Charging

Battery charging starts only after the AAT3620 checks several conditions in order to maintain a safe charging environment. The input supply must be above the minimum operating voltage (UVLO) and above the battery voltage by 0.3V, the battery temperature must be within

the 0°C ~ 45°C range, and the enable pin must be high. The AAT3620 checks the condition of the battery and determines which charging mode to apply. If the battery voltage is below V_{BAT_BC} , the AAT3620 begins battery conditioning until the battery voltage reaches V_{BAT_BC} . The battery conditioning current is 10% of constant current level. At this point the AAT3620 begins constant current mode charging. The constant current mode current level is programmed using a single resistor from the ISET pin to ground. Programmed current can be set from a minimum of 1A to a maximum of 2.0A. Constant current charging will continue until the battery voltage reaches the voltage regulation point V_{BAT_REG} . When the battery voltage reaches V_{BAT_REG} , the AAT3620 will transition to constant-voltage mode. The regulation voltage is factory programmed to a nominal 4.2V and will continue charging until the charging current has reduced to the termination current programmed by the resistor connected from ITERM to ground. The termination current program range is from 50mA to 200mA. After the charge cycle is complete, the AAT3620, turns off the series pass device and automatically goes into a power saving sleep mode. During this time the series pass device will block current in both directions therefore preventing the battery from discharging through the IC.

The AAT3620 will remain in sleep mode, even if the charger source is disconnected, until either the battery terminal voltage drops below the V_{BAT_RCH} threshold, the charger EN pin is recycled, or the charging source is reconnected. In all cases the AAT3620 will monitor all parameters and resume charging in the most appropriate mode.

Figure 1 illustrates the entire battery charging profile, which consists of three phases.

1. Preconditioning-Current Mode (Trickle) Charge
2. Constant-Current Mode Charge
3. Constant-Voltage Mode Charge

The battery preconditioning current is equal to 10% of the constant current charging level, so the battery preconditioning current set range is 100mA to 200mA. Linear mode is on standby while switch-mode is active in the constant current charging region $2.6V < V_{BAT} < 4.2V$. The charger will re-enter linear mode while in constant voltage mode after the switch-mode current drops below 300mA. The termination current is programmed by an external resistor with a separate ITERM pin and the termination current set pin also monitors the charge current. The output short circuit current is equal to the battery preconditioning current.

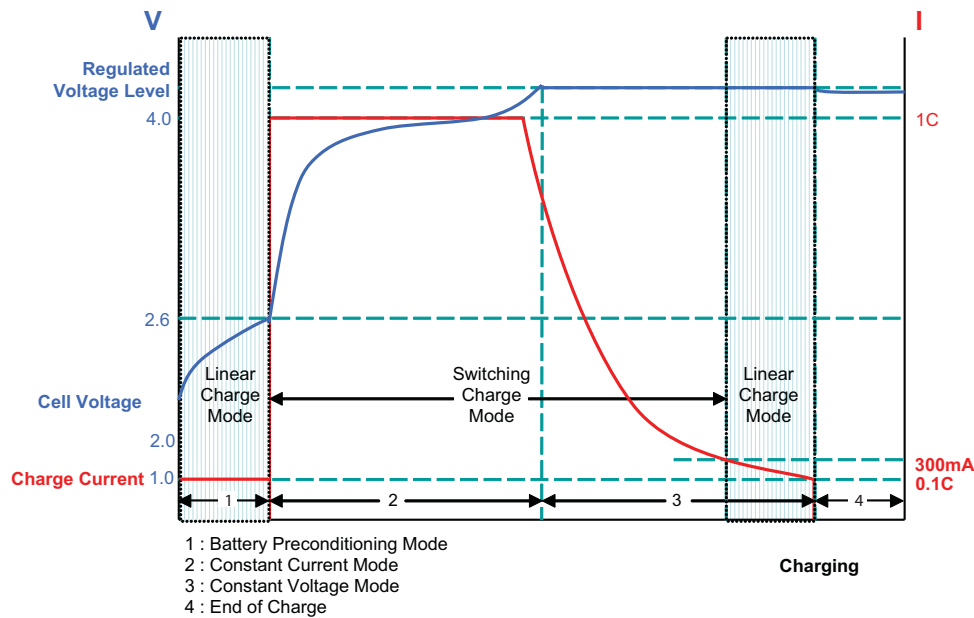
Figure 1: Current vs. Voltage and Charger Time Profile.

Preconditioning Trickle Charge

Battery charging commences only after the AAT3620 battery charger checks several conditions in order to maintain a safe charging environment. The System operation flow chart for the battery charger operation is shown in Figure 4. The input supply must be above the minimum operating voltage (UVLO) and the enable pin (\overline{EN}) must be low (it is internally pulled up). When the battery is connected to the BAT pin, the battery charger checks the condition of the battery and determines which charging mode to apply.

Preconditioning-Current Mode Charge Current

If the battery voltage is below the Preconditioning Voltage Threshold V_{CH_BC} , the battery charger initiates precondition trickle charge mode and charges the battery at 10% of the programmed constant-current magnitude. For example, if the programmed current is 1A, the trickle charge current will be 100mA. Trickle charge is a safety precaution for a deeply discharged cell. It also reduces the power dissipation in the internal series pass MOSFET when the input-output voltage differential is at its highest.

Constant-Current Mode Charge Current

Trickle charge continues until the battery voltage reaches V_{BAT_BC} . At this point the battery charger begins constant-current charging. The current level default for this mode is programmed using a resistor from the ISET pin to ground. Programmed current can be set at a minimum of 100mA and up to a maximum of 2.0A.

The AAT3620 contains a high performance 2A, 1.5MHz synchronous step-down converter. The step-down converter operates to ensure high efficiency performance over all load conditions. It requires only 3 external power components (C_{IN} , C_{OUT} , and L).

Constant-Voltage Mode Charge

Constant current charging will continue until the battery voltage reaches the Output charge voltage regulation point V_{BAT_REG} . When the battery voltage reaches V_{BAT_REG} , the battery charger transitions to constant-voltage mode. V_{BAT_REG} is factory programmed to 4.2V (nominal). Charging in constant-voltage mode will continue until the charge current has reduced to the programmed end of charge termination current.

System Operation Flowchart

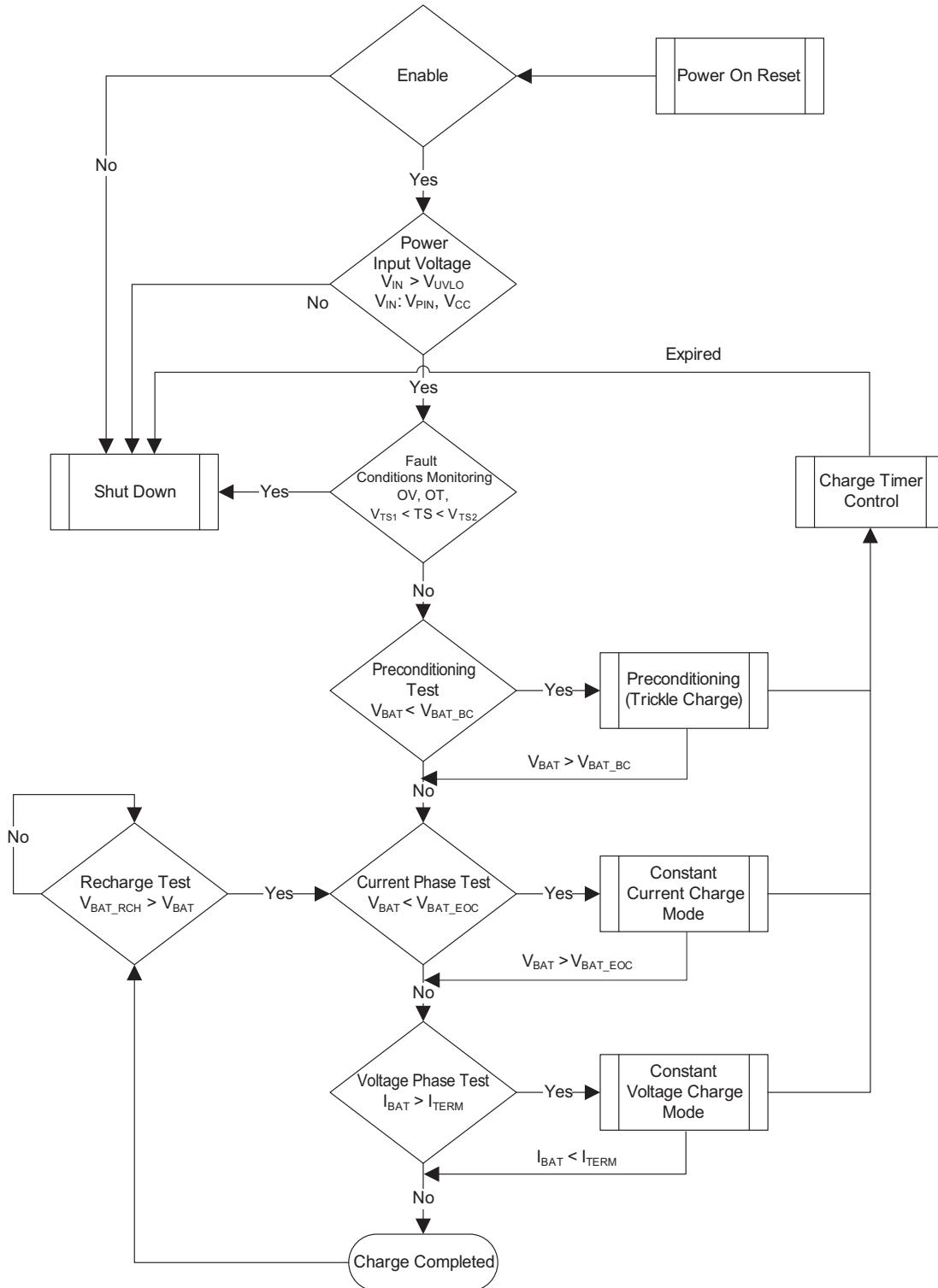

Figure 2: System Operation Flowchart for the Battery Charger.

Power Saving Mode

After the charge cycle is complete, the battery charger turns off the series pass device and automatically goes into a power saving sleep mode. During this time, the series pass device will block current in both directions to prevent the battery from discharging through the battery charger.

The battery charger will remain in sleep mode even if the charger source is disconnected. It will come out of sleep mode if either the battery terminal voltage drops below the V_{BAT_RCH} threshold, the charger EN pin is recycled, or the charging source is reconnected. In all cases, the battery charger will monitor all parameters and resume charging in the most appropriate mode.

Programming Charge Current (ISET)

The default constant current mode charge level is user programmed with a set resistor placed between the ISET pin and ground. The accuracy of the constant charge current, as well as the preconditioning trickle charge current, is dominated by the tolerance of the set resistor. For this reason, a 1% tolerance metal film resistor is recommended for the set resistor function. The constant charge current levels from 1A to 2A may be set by selecting the appropriate resistor value from Table 1 and Figure 3.

Constant Charging Current I_{CH_CC} (mA)	Set Resistor Value (kΩ)
1000	50
1100	55
1200	60
1300	65
1400	70
1500	75
1600	80
1700	85
1800	90
1900	95
2000	100

Table 1: Constant Current Charge vs. I_{SET} Resistor Value.

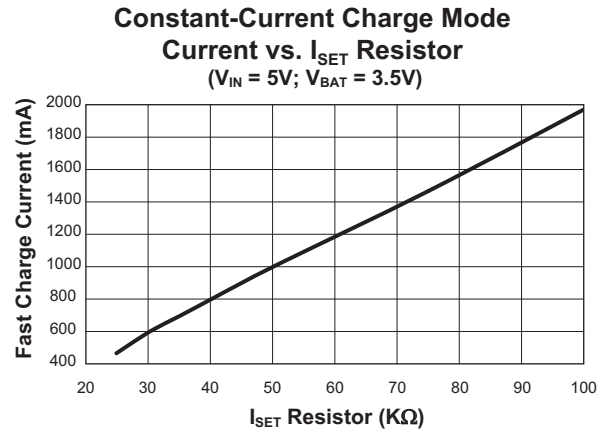

Figure 3: Constant-Current Mode Charge I_{CH_CC} Setting vs. I_{SET} Resistor.

Programmable Charge Termination Current

The charge termination current I_{TERM} can be programmed by connecting a resistor from TERM to GND:

$$I_{TERM} = R_{TERM} \cdot 10^{-6}$$

If the TERM pin is left open, the termination current will set to 200mA as the default value.

When the charge current drops to the defaulted 10% of the programmed charge current level or programmed terminated current in the constant voltage mode, the device terminates charging and goes into a sleep state. The charger will remain in this sleep state until the battery voltage decreases to a level below the battery recharge voltage threshold (V_{BAT_RCH}).

Consuming very low current in sleep state, the AAT3620 minimizes battery drain when it is not charging. This feature is particularly useful in applications where the input supply level may fall below the battery charge or under-voltage lockout level. In such cases where the AAT3620 input voltage drops, the device will enter sleep state and automatically resume charging once the input supply has recovered from the fault condition.

The TERM pin can also be used as a charge current monitor based on the following equation:

$$\text{Charge Current Voltage Level} = 1A/V$$

Status Indicator (STAT1/2)

Charge Status Output

The AAT3620 provides battery charge status via two status pins (STAT1 and STAT2). Each of the two pins is internally connected to an N-channel open drain MOSFET. The status pins can indicate the following conditions:

Option 1: Default Option	STAT1	STAT1 (50% Duty Cycle)	STAT2	STAT2 (50% Duty Cycle)
Pre-Charge	ON		ON	
Fast-Charge	ON		OFF	
End of Charge (Charge Complete)	OFF		ON	
Charge Disabled	OFF		OFF	
Sleep Mode	OFF		OFF	
No Battery (with Charge Enabled)		ON		ON
Fault Condition (Battery 0V)	OFF		OFF	
Fault Condition (Battery OT/UT)	OFF		OFF	
Fault Condition (Device OT)	OFF		OFF	
Fault (Time Out)	OFF		OFF	
TERM (Current reached in CVM)	OFF		OFF	
Option 2	STAT1	STAT1 (50%)	STAT2	STAT2 (50%)
Pre-Charge	ON		OFF	
Fast-Charge	ON		OFF	
End of Charge (Charge Complete)	OFF		OFF	
Charge Disabled	OFF		OFF	
Sleep Mode	OFF		OFF	
No Battery (with Charge Enabled)		ON	OFF	
Fault Condition (Battery 0V)	OFF		ON	
Fault Condition (Battery OT/UT)	ON		ON	
Fault Condition (Device OT)	ON		ON	
Fault (Time Out)	OFF		ON	
TERM (Current reached in CVM)	OFF		OFF	

Table 2: Constant Current Charge vs. ISET Resistor Value.

The LEDs should be biased with as little current as necessary to create reasonable illumination; therefore, a ballast resistor should be placed between the LED cathode and the STAT pins. LED current consumption will add to the overall thermal power budget for the device package, hence it is good to keep the LED drive current to a minimum. 2mA should be sufficient to drive most low cost green or red LEDs. It is not recommended to exceed 8mA for driving an individual status LED. The required ballast resistor values can be estimated using the following formula:

$$R_{\text{BALLAST}} = \frac{(V_{\text{IN}} - V_{\text{F(LED)}})}{I_{\text{LED}}}$$

Example:

$$R_{\text{BALLAST}} = \frac{(5.0\text{V} - 2.0\text{V})}{2\text{mA}} = 1.5\text{k}\Omega$$

Note: Red LED forward voltage (V_F) is typically 2.0V @ 2mA.

Protection Circuitry

Charge Safety Timer (CT)

While monitoring the charge cycle, the AAT3620 utilizes a charge safety timer to help identify damaged cells and to ensure that the cell is charged safely. Operation is as follows: upon initiating a charging cycle, the AAT3620 charges the cell at 10% of the programmed maximum charge until $V_{\text{BAT}} > 2.6\text{V}$. If the cell voltage fails to the precondition threshold of 2.6V (typ) before the safety timer expires, the cell is assumed to be damaged and the charge cycle terminates. If the cell voltage exceeds 2.6V prior to the expiration of the timer, the charge cycle proceeds into fast charge. Three timeout periods of 25 minutes for Trickle Charge mode, 2 hours for Constant Current Mode and 3 hours for Constant Voltage mode.

Mode	Time
Trickle Charge (TC) Time Out	25 minutes
Trickle Charge (TC) + Constant Current (CC) Mode Time Out	2 hours
Constant Voltage (VC) Mode Time Out	3 hours

Table 3: Summary for a 0.1µF Ceramic Capacitor Used for the Timing Capacitor.

The AAT3620 has a battery fault detector, which, when used in conjunction with a 0.1µF capacitor on the CT pin, outputs a 1Hz signal with 50% duty cycle at the STAT1 pin in the event of a timeout while in the trickle charge mode.

The CT pin is driven by a constant current source and will provide a linear response to increases in the timing capacitor value. Thus, if the timing capacitor were to be doubled from the nominal 0.1µF value, the time-out periods would be doubled. If the programmable watchdog timer function is not needed, it can be disabled by terminating the CT pin to ground. The CT pin should not be left floating or unterminated, as this will cause errors in the internal timing control circuit. The constant current provided to charge the timing capacitor is very small, and this pin is susceptible to noise and changes in capacitance value. Therefore, the timing capacitor should be physically located on the printed circuit board layout as close as possible to the CT pin. Since the accuracy of the internal timer is dominated by the capacitance value, a 10% tolerance or better ceramic capacitor is recommended. Ceramic capacitor materials, such as X7R and X5R types, are a good choice for this application.

Over-Voltage Protection

An over-voltage event is defined as a condition where the voltage on the BAT pin exceeds the maximum battery charge voltage and is set by the over-voltage protection threshold (V_{BAT_OVP}). If an over-voltage condition occurs, the AAT3620 charge control will shut down the device until the voltage on the BAT pin drops below V_{BAT_OVP} . The AAT3620 will resume normal charging operation after the over-voltage condition is removed. During an over-voltage event, the STAT LEDs will report a system fault.

Over-Temperature Shutdown

The AAT3620 has a thermal protection control circuit which will shut down charging functions should the internal die temperature exceed the preset thermal limit threshold. Once the internal die temperature falls below the thermal limit, normal operation will resume the previous charging state.

Battery Temperature Fault Monitoring (TS)

In the event of a battery over-temperature condition, the charge control will turn off the internal pass device and report a battery temperature fault on the STAT pins. After the system recovers from a temperature fault, the device will resume charging operation. The AAT3620 checks battery temperature before starting the charge cycle, as well as during all stages of charging. This is accomplished by monitoring the voltage at the TS pin. The internal battery temperature sensing system (Figure 3) is comprised of two comparators which establish a voltage window for safe operation. The thresholds for the TS operating window are bounded by the V_{TS1} and V_{TS2} specifications. Referring to the electrical characteristics table in this datasheet, the V_{TS1} threshold = $0.30 \cdot V_{IN}$ and the V_{TS2} threshold = $0.60 \cdot V_{IN}$. An external resistor R_T with a value equal to the NTC thermistor resistance must be connected between TS and V_{IN} .

This system is intended for use with negative temperature coefficient thermistors (NTC) which are typically integrated into the battery package. Most of the commonly used NTC thermistors in battery packs are approximately 10kΩ at room temperature (25°C). If the battery becomes too hot during charging due to an internal fault or excessive constant charge current, the thermistor will heat up and reduce in value, pulling the TS pin voltage lower than the TS1 threshold, and the AAT3620 will stop charging until the condition is removed, when charging will be resumed. If the use of the TS pin function is not required by the system, it should be tied to VPIN using a 10kΩ resistor.

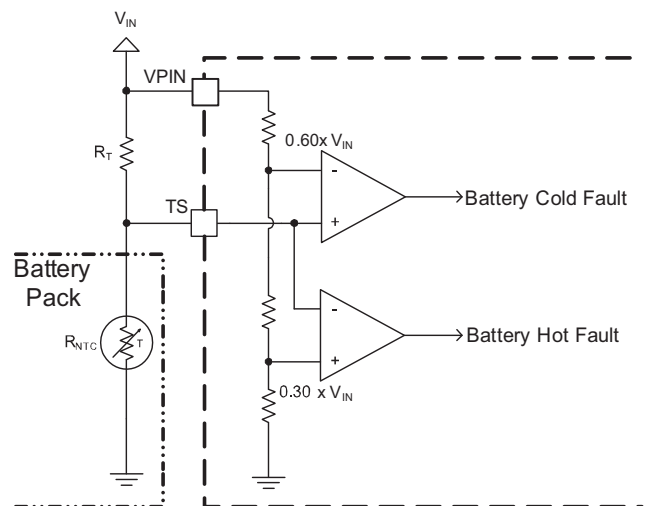

Figure 3: AAT3620 Battery Temperature Sense Circuit.

Thermal Considerations

The actual maximum charging current is a function of Charge Adapter input voltage, the state of charge of the battery at the moment of charge, the system supply current from the BAT pin, the ambient temperature and the thermal impedance of the package. The maximum programmable current may not be achievable under all operating parameters.

The AAT3620 is offered in a TDFN33-14 package which can provide up to 2W of power dissipation when it is properly bonded to a printed circuit board and has a maximum thermal resistance of 50°C/W. Many considerations should be taken into account when designing the printed circuit board layout, as well as the placement of the charger IC package in proximity to other heat generating devices in a given application design. The ambient temperature around the charger IC will also have an effect on the thermal limits of a battery charging application. The maximum limits that can be expected for a given ambient condition can be estimated by the following discussion. First, the maximum power dissipation for a given situation should be calculated:

$$P_{D(MAX)} = \frac{(T_{J(MAX)} - T_A)}{\theta_{JA}}$$

Where:

$P_{D(MAX)}$ = Maximum Power Dissipation (W)
 θ_{JA} = Package Thermal Resistance (°C/W)
 $T_{J(MAX)}$ = Maximum Device Thermal Shutdown Temperature (°C) [140°C]
 T_A = Ambient Temperature (°C)

The power dissipation for both the linear charging mode and the switching charger mode should be considered.

The power dissipation for the switching charger can be calculated by the following equation:

$$P_{D(MAX)} = \frac{I_{CH_CC}^2 \cdot [R_{DS(ON)HS} \cdot V_{BAT} + R_{DS(ON)LS} \cdot (V_{PIN} - V_{BAT})]}{V_{PIN}} + [(t_{SW} \cdot f_{SW} \cdot I_{CH_CC} + I_{QOP}) \cdot V_{PIN}]$$

Where:

$P_{D(MAX)}$ = Total Power Dissipation by the Device
 V_{PIN} = Adapter Input Voltage
 V_{BAT} = Battery Voltage at the BAT Pin
 I_{CH_CC} = Constant Charge Current Programmed for the Application

I_{QOP} = Quiescent Current Consumed by the IC for Normal Operation [5mA]

$R_{DS(ON)HS}$ and $R_{DS(ON)LS}$ = On-resistance of step-down high and low side MOSFETs

The power dissipation for the linear charging mode can be calculated by the following equation:

$$P_{D(MAX)} = [(V_{PIN} - V_{BAT}) \cdot I_{CH_BC} + (V_{PIN} \cdot I_{QOP})]$$

Where:

$P_{D(MAX)}$ = Total Power Dissipation by the Device
 V_{PIN} = Input Voltage
 V_{BAT} = Battery Voltage as Seen at the BAT Pin
 I_{CH_BC} = Battery Conditioning Charge Current Programmed for the Application
 I_{QOP} = Quiescent Current Consumed by the Charger IC for Normal Operation [5mA]

By substitution, we can derive the maximum charge current before reaching the thermal limit condition (thermal loop). The maximum charge current is the key factor when designing battery charger applications.

$$I_{CH_BC(MAX)} = \frac{(P_{D(MAX)} - T_A \cdot I_{QOP})}{V_{PIN} - V_{BAT}}$$

$$I_{CH(MAX)} = \frac{\left(\frac{(T_J - T_A)}{\theta_{JA}} - V_{IN} - I_{OP} \right)}{V_{IN} - V_{BAT}}$$

In general, the worst condition is the greatest voltage drop across the charger IC, when battery voltage is charged up to the preconditioning voltage threshold and entering Constant Current switching charge mode.

Example Worst Case Power Dissipation

The worst case power dissipation can be calculated using the lowest battery voltage level when the charger enters CC charge mode and the charge current is set to 2A.

$I_{CH_CC} = 2A$
 $V_{PIN} = 6V$
 $R_{DS(ON)HS} = 0.3\Omega$
 $R_{DS(ON)LS} = 0.25\Omega$
 $t_{SW} = 5 \cdot 10^{-9}$
 $I_{QOP} = 0.005A$
 $f_{SW} = 1.5 \cdot 10^6$
 $T_A = 85^\circ C$
 $\theta_{JA} = 50^\circ C/W$

$$P_{D(MAX)} = \frac{(2A)^2 \cdot [0.3\Omega \cdot 2.8V + 0.25\Omega \cdot (6V - 2.8V)]}{6V} + [(5 \cdot 10^{-9} \cdot [1.5 \cdot 10^6] \cdot 2A + 0.005A) \cdot 6V]$$

$$P_{D(MAX)} = 1.213W$$

$$T_{J(MAX)} = 85 + 50 \cdot 1.213$$

$$T_{J(MAX)} = 145.65$$

For the Linear Mode:

$$I_{QOP} = 0.005A$$

$$V_{PIN} = 6V$$

$$V_{BAT} = 2V$$

$$I_{CH_BC} = 0.2A$$

$$P_{D(MAX)} = [(6V - 2V) \cdot 0.2A + (6V \cdot 0.005A)]$$

$$P_{D(MAX)} = 0.83W$$

Layout Guidance

Figure 5 is the evaluation board schematic. The evaluation board has additional components for easy evaluation; the actual bill of materials required for the system is shown in Table 4. When laying out the PC board, the

following layout guidelines should be followed to ensure proper operation of the AAT3620:

1. The exposed pad EP must be reliably soldered to PGND/AGND and multilayer GND. The exposed thermal pad should be connected to board ground plane and pins 2 and 3. The ground plane should include a large exposed copper pad under the package with vias to all board layers for thermal dissipation.
2. The power traces, including GND traces, the LX traces and the VIN trace should be kept short, direct and wide to allow large current flow. The L1 connection to the LX pins should be as short as possible. Use several via pads when routing between layers.
3. The input capacitors (C1, C5, C6, and C7) should be connected as close as possible to VPIN (Pin 1) VCC (Pin 4) and GND/PGND (Pin 2,3) to get good power filtering.
4. The output capacitors C2, C4, and C9 and inductor L1 should be connected as close as possible and there should not be any signal lines under the inductor.
5. The resistance of the trace from the load return to the PGND (Pin 2) should be kept to a minimum. This will help to minimize any error in DC regulation due to differences in the potential of the internal signal ground and the power ground.

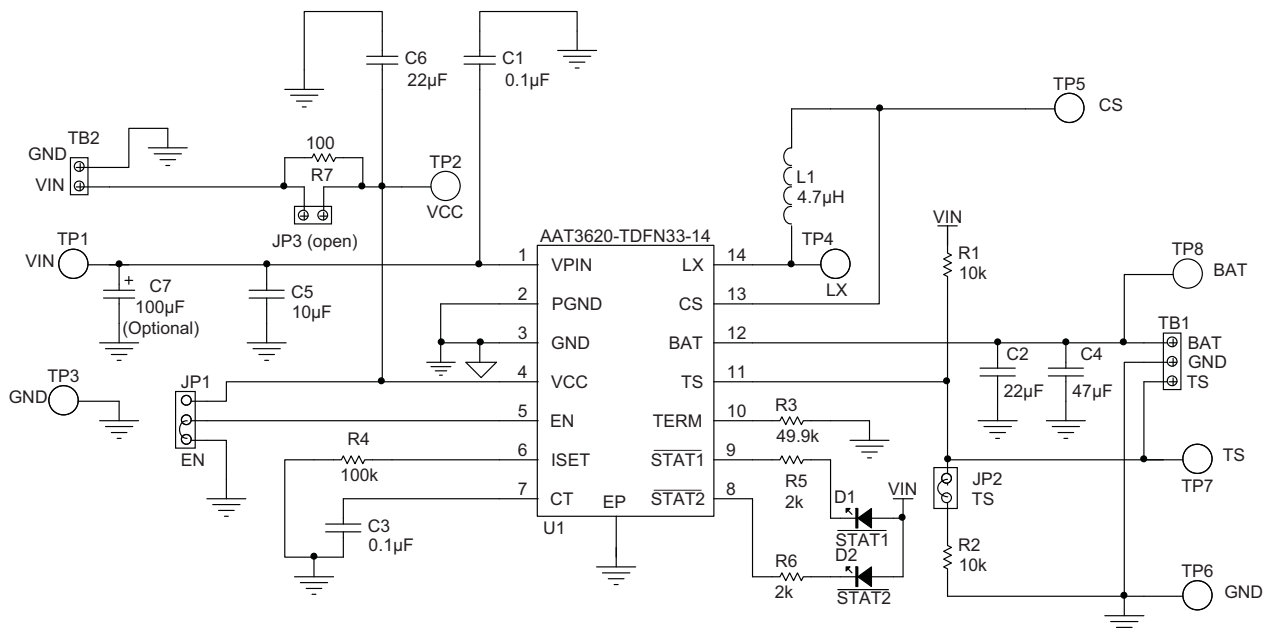

Figure 5: AAT3620 2A Evaluation Kit Schematic.

Quantity	Value	Designator	Footprint	Description
1	10μF	C5	0603	Capacitor, Ceramic, X5R, 10V, ±20%
2	0.1μF	C1, C3	0402	Capacitor, Ceramic, 20%, 10V, X5R
2	22μF	C2, C6	1206	Capacitor, Ceramic, 20%, 10V, X5R
1 (Optional)	100μF	C10	C	Capacitor, Tantalum, 16V, 10%
1	47μF	C4	1206	Capacitor, Ceramic, 20%, 10V, X5R
1	4.7μH	L1	7mm x 7mm	Inductor, Würth, 7447789004
2	10K	R1, R2	0402	Resistor, 5%
2	2k	R5, R6	0402	Resistor, 5%
1	49.9k	R3	0402	Resistor, 1%
1	100k	R4	0402	Resistor, 1%
1	100	R7	0402	Resistor, 1%
2	LED	D1, D2	0402	Red and Green SMD

Table 4: Minimum AAT3620 Bill of Materials.

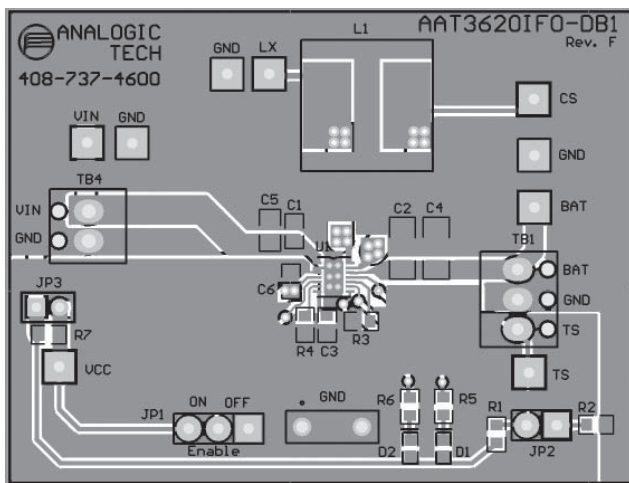

Figure 6: AAT3620 Evaluation Kit Top Layer.

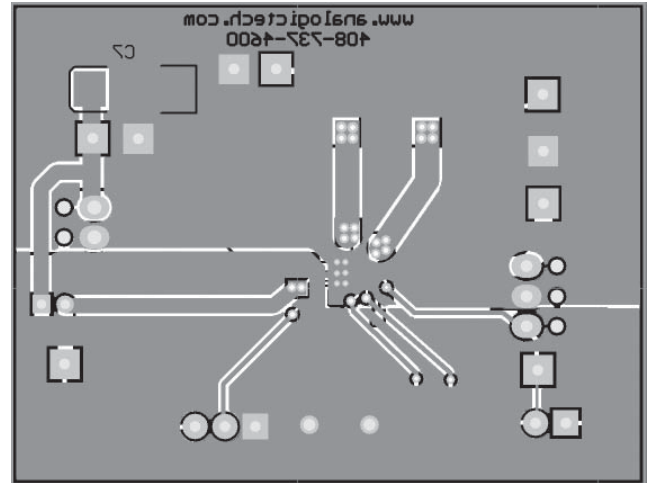

Figure 7: AAT3620 Evaluation Kit Bottom Layer.

Ordering Information

Package	Part Marking ¹	Part Number (Tape and Reel) ²
TDFN33-14	6WXY	AAT3620IWO-4.2-T1



All AnalogicTech products are offered in Pb-free packaging. The term “Pb-free” means semiconductor products that are in compliance with current RoHS standards, including the requirement that lead not exceed 0.1% by weight in homogeneous materials. For more information, please visit our website at <http://www.analogictech.com/about/quality.aspx>.

Packaging Information

TDFN33-14

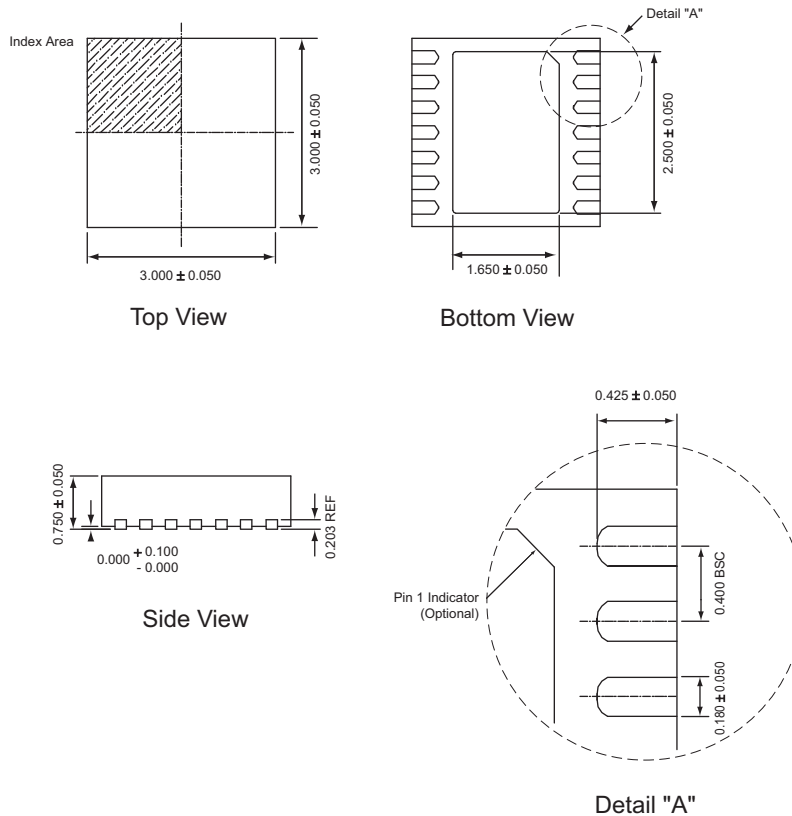

1. XYY = assembly and date code.
 2. Sample stock is generally held on part numbers listed in BOLD.
 3. The leadless package family, which includes QFN, TQFN, DFN, TDFN and STDFN, has exposed copper (unplated) at the end of the lead terminals due to the manufacturing process. A solder fillet at the exposed copper edge cannot be guaranteed and is not required to ensure a proper bottom solder connection.

**BatteryManager™****I-Cell Li+ Switch Mode Battery Charger**

Advanced Analogic Technologies, Inc.
3230 Scott Boulevard, Santa Clara, CA 95054
Phone (408) 737-4600
Fax (408) 737-4611



© Advanced Analogic Technologies, Inc.
AnalogicTech cannot assume responsibility for use of any circuitry other than circuitry entirely embodied in an AnalogicTech product. No circuit patent licenses, copyrights, mask work rights, or other intellectual property rights are implied. AnalogicTech reserves the right to make changes to their products or specifications or to discontinue any product or service without notice. Except as provided in AnalogicTech's terms and conditions of sale, AnalogicTech assumes no liability whatsoever, and AnalogicTech disclaims any express or implied warranty relating to the sale and/or use of AnalogicTech products including liability or warranties relating to fitness for a particular purpose, merchantability, or infringement of any patent, copyright or other intellectual property right. In order to minimize risks associated with the customer's applications, adequate design and operating safeguards must be provided by the customer to minimize inherent or procedural hazards. Testing and other quality control techniques are utilized to the extent AnalogicTech deems necessary to support this warranty. Specific testing of all parameters of each device is not necessarily performed. AnalogicTech and the AnalogicTech logo are trademarks of Advanced Analogic Technologies Incorporated. All other brand and product names appearing in this document are registered trademarks or trademarks of their respective holders.